

UPS

CT 382 - B

CT 682 - B

CT 1082 - B

CT 1382 - B

CT 1682 - B

**UNINTERRUPTIBLE
POWER
SUPPLIES**

CT - SERIES

ICA



**USER MANUAL
(BUKU PETUNJUK PEMAKAIAN)**

CONTENTS / *DAFTAR ISI*

	<i>Page / Halaman</i>
I. SAFETY NOTES / <i>CATATAN KESELAMATAN</i>	1
II. INTRODUCTION / <i>PENDAHULUAN</i>	3
III. TECHNICAL SPECIFICATION / <i>SPESIFIKASI TEKNIK</i>	4
IV. FRONT PANEL & REAR PANEL VIEW / <i>TAMPAK PANEL DEPAN & PANEL BELAKANG</i>	5
V. INSTALLATION / <i>INSTALASI</i>	7
VI. START UP UPS / <i>MENGHIDUPKAN UPS</i>	8
VII. OPERATION PROCEDURE / <i>CARA MENGOPERASIKAN</i>	9
VIII. TABLE OF INDICATOR STATUS / <i>TABEL STATUS INDIKATOR</i>	10
IX. TROUBLESHOOTING / <i>KETIDAKNORMALAN</i>	11

I. SAFETY NOTES / CATATAN KESELAMATAN

I.1. Electrical Safety

- Do not work alone under hazardous conditions.
- High current through conductive materials could cause severe burns.
- Check that the power cord(s), plug(s), and socket are in good condition.
- When grounding cannot be verified, disconnect the equipment from the utility power outlet before installing or connecting to other equipment. Reconnect the power cord only after all connections are made.
- Connect the equipment to a three wire utility outlet (two pole plus ground). The receptacle must be connected to appropriate branch circuit/ mains protection (fuse or circuit breaker). Connection to any other type of receptacle may result in risk of electrical shock.

I.2. Deenergizing Safety

- If the UPS has an internal energy source (battery), the output may be energized when the unit is not connected to a utility power outlet.
- To deenergize a pluggable UPS, press the OFF button or switch to shut the equipment off. Unplug the UPS from the utility power outlet. Disconnect the external batteries where applicable and disconnect the internal battery. Push the ON button to deenergize the capacitors.

I.1. Keselamatan Listrik

- Jangan bekerja sendiri dalam situasi berbahaya.
- Tegangan tinggi melalui bahan konduktif dapat menyebabkan luka bakar.
- Periksa agar kabel listrik, fitting, dan soket berada dalam kondisi baik.
- Bila grounding tak dapat diverifikasi, putus hubungan peralatan listrik dengan keluaran listrik AC sebelum memasang atau menghubungkannya dengan peralatan lain. Hubungkan kembali dengan kabel listrik hanya jika seluruhnya selesai dihubungkan.
- Hubungkan peralatan ke keluaran listrik AC tiga kabel (dua kutub dan ground). Soket penerima harus terhubung secara benar melalui sirkuit cabang/pelindung utama (sekring atau pemutus arus). Hubungan ke soket penerima dalam bentuk lainnya dapat menyebabkan bahaya sengatan listrik.

I.2. Keselamatan Saat Membuang Arus Listrik

- Jika alat memiliki sumber energi internal (baterai), output mungkin masih mengandung arus listrik walaupun unit tidak terhubung dengan tegangan listrik AC.
- Untuk membuang arus listrik dari UPS yang terhubung, tekan tombol OFF untuk mematikan alat. Putuskan alat dari outlet listrik AC. Lepaskan baterai dan putus baterai internal. Tekan tombol ON untuk membuang listrik di dalam kapasitor.

I.3. Battery Safety

- Repair are to be performed only by qualified personnel.
- Do not dispose of batteries in a fire. The batteries may explode.
- Do not open or mutilate batteries. They contain an electrolyte that is toxic and harmful to the skin and eyes.
- Replace batteries with the same number and type of batteries as originally installed in the equipment.

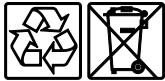

Do not dispose of leftover packaging for this product as household waste: Take it to a collection point for recycling. For information about the nearest recycling facility, contact your local waste disposal authority.

Disposing of the product

The UPS contains internal material that (in case of disposal) are considered TOXIC and HAZARDOUS WASTE, such as electronic circuit boards and batteries. Treat these materials according to the laws applicable referring to qualified service personnel. Their proper disposal contributes to respect the environment and human health.

I.3. Keselamatan Baterai

- Perbaikan hanya dilakukan oleh seorang teknisi yang memiliki kualifikasi.
- Jangan buang baterai ke dalam api, dapat meledak.
- Jangan membongkar baterai. Baterai mengandung elektrolit yang beracun dan dapat merusak kulit dan mata.
- Ganti baterai dengan nomor dan jenis yang sama seperti aslinya terpasang dalam alat.

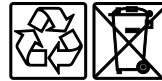

Jangan buang sisa kemasan produk ini sebagai limbah rumah tangga: Bawa ke tempat pengumpulan untuk didaur ulang. Untuk informasi tentang tempat daur ulang terdekat, hubungi petugas pembuangan limbah setempat.

Pembuangan produk

UPS berisi bahan internal yang (dalam kasus pembuangan) dianggap LIMBAH BERACUN dan BERBAHAYA, seperti papan sirkuit elektronik dan baterai. Perlakukan bahan-bahan ini sesuai dengan undang-undang yang berlaku dengan merujuk pada personel servis yang berkualifikasi. Pembuangan yang tepat berkontribusi untuk menghormati lingkungan dan kesehatan manusia.

II. INTRODUCTION / PENDAHULUAN

UPS (Uninterruptible Power Supplies) can provide full protection against all of power problem for your sensitive equipment ranging from computer, computerized instrument, PABX, facsimile, cash register to all electronic equipment.

This UPS consists of inverter, batteries, battery charger, control circuit, stabilizer, transfer switch and indicator. When line power is normal, the UPS filters line power input and by pass to output UPS and at the same time the batteries is being charged by battery charger. And when line power fails (off, voltage too low), inverter will supply regulated AC power to the load within ≤ 4 ms transfer time so that the power supplied to the load is uninterrupted. And when line power is normal automatically load gets from line power again.

UPS (Uninterruptible Power Supplies) dapat melindungi peralatan anda yang rentan terhadap gangguan kelistrikan seperti computer, instrument terkomputerisasi, PABX, faksimili, cash register dan peralatan elektronik lainnya.

UPS ini terdiri atas inverter, baterai, pengisi baterai, rangkaian pengendali, stabilisator, saklar pengalih dan indikator. Saat listrik jala-jala normal, UPS menyaring listrik masukan dan menyalurkannya pada keluaran UPS, pada saat yang sama baterai diisi oleh pengisi baterai. Manakala terjadi gangguan listrik (padam, tegangan terlalu rendah), inverter seketika bekerja dengan waktu alih ≤ 4 ms sehingga pasokan listrik pada beban tidak terganggu / terputus. Dan bila listrik jala-jala pulih maka otomatis beban mendapat daya listrik jala-jala kembali.

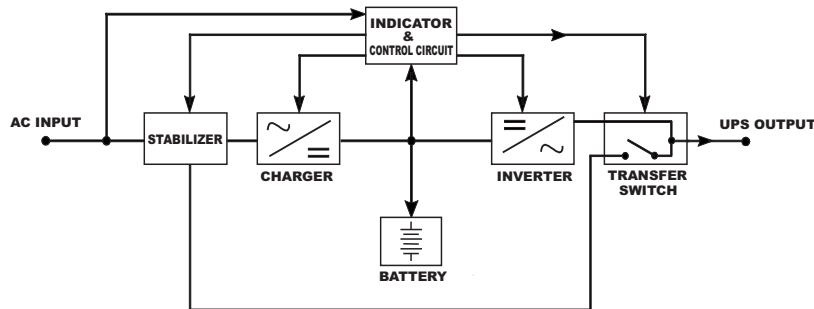

III. TECHNICAL SPECIFICATION / SPESIFIKASI TEKNIK

ITEM		UNIT	SPECIFICATIONS					REMARKS
MODEL			CT382B	CT682B	CT1082B	CT1382B	CT1682B	
AC IN	Voltage	V	160 - 250					Max. Load & Charger
	Current	A	1,6	2,9	4,8	6,2	7,7	
	Frequency	Hz	50 ± 3					
	Protection	A	3,15	6,3	10			
DC IN	Internal Battery		1x12V, 7AH	2x12V, 7AH	3x12V, 7AH	4x12V, 7AH	5x12V, 7AH	Sealed Lead Acid Battery
	Protection	A	30	50				Fuse
INV. OUT	Wave Form		SYNTHESIZED SINEWAVE (STEP WAVE)					PWM
	Voltage	V	220 ± 5%					
	Frequency	Hz	50					
	Power	VA/W	600/300	1200/600	2000/1000	2600/1300	3200/1600	Maximum
	Efficiency	%	> 80					
CHG	Type		Constant Voltage					
	Voltage	V	13,5	27,0	40,5	54,0	67,5	
	Current	A	1,5					Maximum
Transfer Time	ms	≤ 4						
Back Up Time	Minutes	10					Nominal Load	
Indicator		Led and Buzzer					Table of Indicator Status	
Operating Temperature	°C	0 - 40						
Dimension	mm	340x95x145	390x145x195	430x175x230	445x175x230		DxWxH	
Weight	Kg	6	14	20,3	23,5	28	Netto	
		7	15	22	25	30	Gross	

IV. FRONT PANEL & REAR PANEL VIEW / *TAMPAK PANEL DEPAN & PANEL BELAKANG*

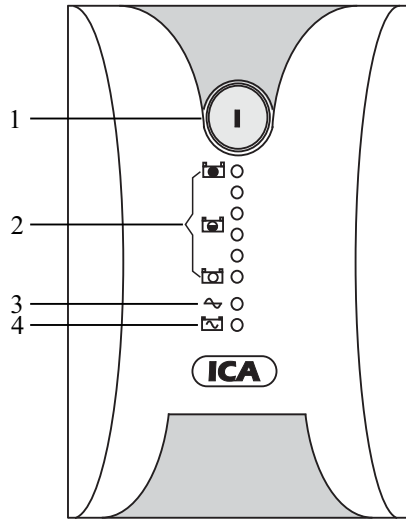

FRONT PANEL VIEW
 UPS CT382B, CT682B, CT1082B,
 CT1382B, CT1682B

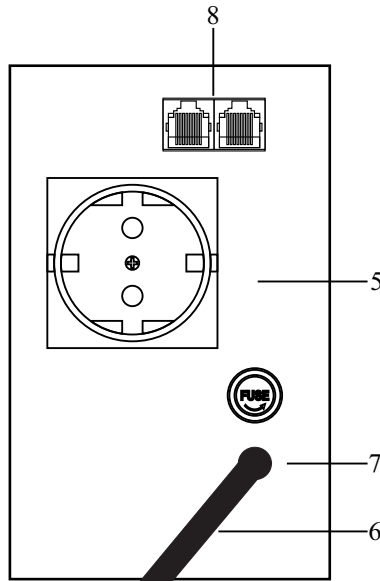

REAR PANEL VIEW
 UPS CT382B

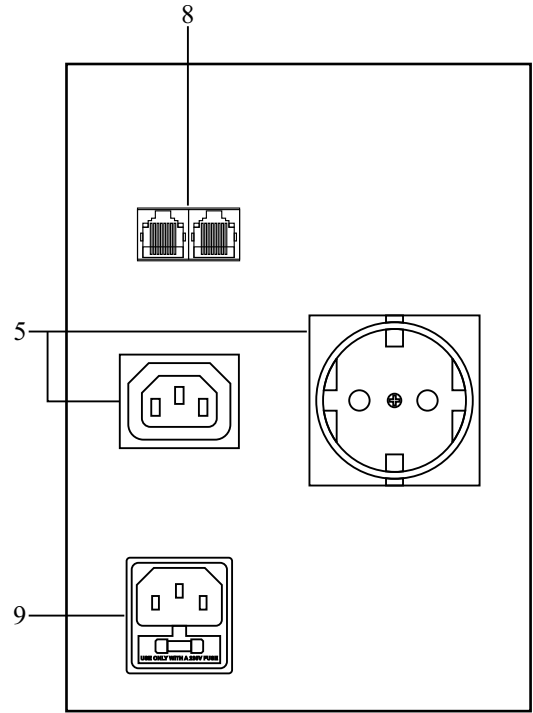

REAR PANEL VIEW
 UPS CT682B

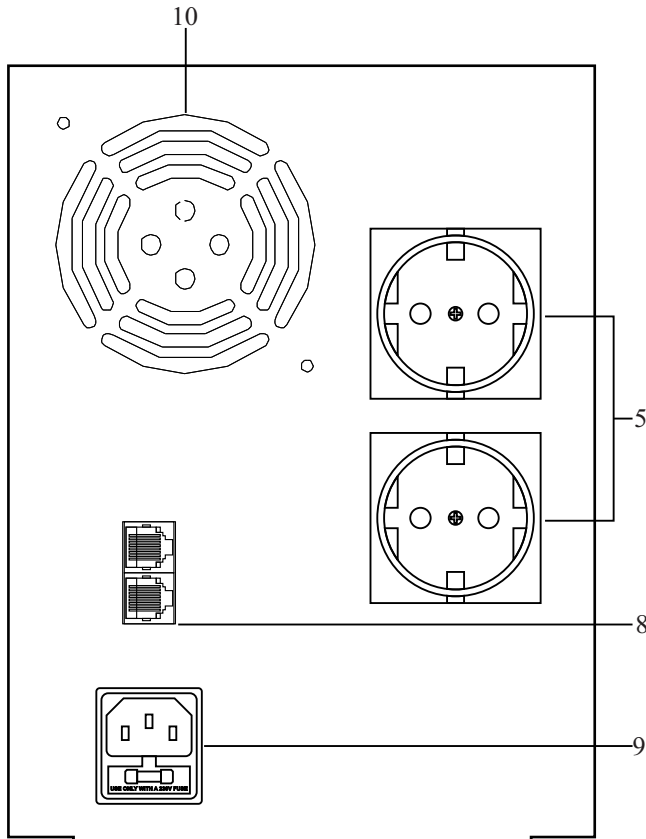

REAR PANEL VIEW
UPS CT1082B, CT1382B,
CT1682B

1. Main Switch / Tombol Daya : To turn on and off the UPS / Untuk menghidupkan dan mematikan UPS
2. Battery level / Taraf baterai : Indicate status of battery (look at Table of Indicator Status) / Menunjukkan keadaan baterai (lihat Tabel Status Indikator)
3. Line on / Listrik : Green led, indicate output UPS from line power / Led hijau, menunjukkan keluaran UPS berasal dari listrik jala-jala
4. Inverter on / Inverter : Yellow led, indicate output UPS from inverter / Led kuning, menunjukkan keluaran UPS berasal dari inverter
5. Outlet / Stopkontak keluaran
6. AC cord input / Kabel input AC
7. Input fuse / Fuse input
8. Modem : Internet modem protection / Perlindungan protector port modem internet
9. Inlet / Stopkontak masukan
10. Ventilation / Lubang angin

* Notice :

Please disconnect all communication connectors before disconnecting main power cord from receptacle.
Putuskan semua konektor komunikasi sebelum mencabut kabel daya utama dari stopkontak.

V. INSTALLATION / *INSTALASI*

V.1 Unpacking and Inspection

- V.1.1 Unpack the packaging and check the package contents. The contains of package ; UPS, user manual, warranty card, and input power cable.
- V.1.2 Inspect the appearance of the UPS to see if there is any damage during transportation. Do not on the unit and notify the carrier and dealer immediately if there is any damage or lacking of some parts.

V.2 UPS Installation

- V.2.1 Location
This UPS Should be located in protected place.
- V.2.2 Installation
This UPS must be connected to a power receptacle with earth ground
 - a. Make sure Main Switch on the off position.
 - b. Connect the UPS to the available outlet.

V.1 Buka kemasan dan Pemeriksaan

- V.1.1 Buka kemasan dan periksa isi kemasannya. Isi dari kemasan; UPS, buku petunjuk, kartu garansi, dan kabel daya input.
- V.1.2 Periksa penampilan UPS untuk mengetahui apakah terdapat kerusakan akibat pengiriman. Jangan menghidupkan unit dan langsung beritahukan kepada agen jika ditemukan kerusakan ataupun kekurangan.

V.2 Instalasi UPS

- V.2.1 Lokasi
Letakkan UPS ini pada tempat yang terlindung.
- V.2.2 Pemasangan
UPS ini harus dipasang pada stopkontak yang mempunyai hubungan ke bumi (arde).
 - a. Pastikan Main Switch pada posisi off.
 - b. Hubungkan UPS dengan stopkontak yang tersedia.

VI. START UP UPS / *MENGHIDUPKAN UPS*

1. Make sure Main Switch on the “off” position and no load is connected to the outlet.
 2. Connect inlet with power cord to a power receptacle with earth ground.
 3. Turn on the UPS by pressing power button. The red led in the BATTERY LEVEL lights for about 5 seconds and will go out when the battery is in good condition. At the same time the green led of LINE ON light (if line voltage >170V) which indicates UPS output is from line power.
 4. Disconnect inlet from line power, the green led of LINE ON will go out while the yellow led of INVERTER will light on.
 5. Connect inlet to line power again and then after about 5 seconds the yellow led of INVERTER will go out while the green led of line on will light on.
 6. Now your UPS is ready for operation. Connect the equipment that is going to be supplied by the UPS into the UPS.
1. Pastikan tombol pada posisi “off” dan tidak ada beban yang terpasang pada stopkontak keluaran.
 2. Hubungkan steker kabel daya ke stopkontak jala-jala yang mempunyai arde.
 3. Hidupkan UPS dengan menekan tombol daya. Led merah pada TARAF BATERAI akan menyala sekitar 5 detik dan padam kembali bila kondisi baterai baik. Bersamaan dengan itu led hijau LISTRIK JALA-JALA menyala (bila tegangannya > 170V) yang menunjukkan keluaran UPS berasal dari listrik jala-jala.
 4. Cabut steker kabel daya dari stopkontak jala-jala maka led hijau LISTRIK JALA-JALA padam sedangkan led kuning INVERTER akan menyala.
 5. Pasang kembali steker maka sekitar 5 detik kemudian led kuning INVERTER padam sedangkan led hijau akan menyala.
 6. Sekarang UPS siap menjalankan fungsinya. Hubungkan peralatan yang akan diberi pasokan daya pada stopkontak keluaran UPS.

VII. OPERATION PROCEDURE / *CARA MENGOPERASIKAN*

1. Turn on procedure.
 - a. Press on power button at the front panel.
 - b. Turn on the load connected to the outlet.
 2. When the line power is interrupted.

In case of line power is interrupted (off or voltage is too low), inverter converts the battery power to AC power automatically with transfer time ≤ 4 ms. Buzzer will sound at interval 4 seconds. When the battery is near the end of its capacity, buzzer will sound continuously. At this time data should be stored and all load shutdown.
 3. Turn off procedure.
 - a. Turn off all the load connected to the outlet.
 - b. Press on power button at the front panel.
1. Cara menghidupkan
 - a. Tekan tombol daya pada panel depan.
 - b. Hidupkan beban yang terpasang pada stopkontak keluaran
 2. Saat listrik jala-jala terganggu.

Saat listrik jala-jala terganggu (padam atau tegangannya terlalu rendah), inverter langsung bekerja dengan waktu alih ≤ 4 ms mengubah daya baterai menjadi arus listrik AC. Buzzer akan berbunyi putus-putus selang 4 detik. Saat baterai hampir habis buzzer akan berbunyi sinambung. Pada saat ini data harus sudah tersimpan dan semua beban harus sudah dimatikan.
 3. Cara mematikan.
 - a. Matikan semua beban yang terpasang pada UPS.
 - b. Tekan tombol daya pada panel depan.

Notes :

The UPS battery should charge for at least 10 hours to ensure sufficient runtime. The unit is being charged whenever it is connected to utility power, and UPS must be turn ON.

Catatan :

Battery UPS harus di isi sekurangnya 10 jam untuk memastikan UPS beroperasi dengan memadai. Unit akan mengisi bilamana dihubungkan dengan sumber listrik, dan UPS harus dihidupkan.

VIII. TABLE OF INDICATOR STATUS / *TABEL STATUS INDIKATOR*

UPS Condition	Power Button	Buzzer			Led								Remarks	
		NP	NTPL	NTPC	L1						L2	L3		
					L11	L12	L13	L14	L15	L16				
Normal	1	0	0	0	X	X	X	X	X	X	0	1	0	
No Line Voltage	1	0	1	0	X	X	X	X	X	X	0	0	1	
Line Voltage too low	1	0	1	0	X	X	X	X	X	X	0	0	1	
Line voltage too high	1	0	0	1	X	X	X	X	X	X	0	1	0	
Normal, battery is full	1	0	0	0	1	1	1	1	1	1	0	1	0	
Inverter is on at low battery voltage	1	1	0	0	0	0	0	0	0	0	1	0	1	Save your work now, the inverter will be cut off
Line Voltage is normal, Battery voltage is low	1	1	0	0	0	0	0	0	0	0	1	1	0	

Remarks :

1 : On

0 : Off

X : Don't care, depends on battery conditions

L1 : Consists of LED (L11, L12, L13, L14, L15, L16)

L2 : Green led (look at page 3 no.3)

L3 : Yellow led (look at page 3 no.4)

NP : Continuous sound

NTPL : Audible alarm sounds every 4 seconds

NTPC : Audible alarm sounds every 1 second

Note :

If indicates out of the table, turn off power button and call for service.

IX. TROUBLE SHOOTING / *KETIDAKNORMALAN*

SYSTEM	PROBLEM CAUSE	RECOMMENDED SOLUTION
“Line on” indicator not light.	<ol style="list-style-type: none">1. Main voltage <160 Vac.2. Problem in transfer switch control.	<ol style="list-style-type: none">1. Check your mains voltage.2. If your main voltage >160 Vac, call for service.
When AC main failure and transfer to stored mode, the backup time is short.	Low battery capacity.	<ol style="list-style-type: none">1. Check battery voltage.2. Charger battery \pm 10 hour by kept the main switch in on position when AC mains normal.3. Call for service.
When AC main failure and transfer to stored mode, unit cut-off immediately.	<ol style="list-style-type: none">1. Battery damage.2. Problem in inverter circuit.	<ol style="list-style-type: none">1. Replace battery with the same rating.2. Call for service.

SERVICE CENTRE
ICA

Jln. Pinangsia Raya I No: 22BB
Jakarta - 11120
Phone : (021) 6906020 (Hunting)



Notes :
For further information, please visit "www.icaups.co.id".

Catatan :
Untuk informasi lebih lanjut, silakan kunjungi "www.icaups.co.id".